

## Front-mounted and mounted disc mowers

---

**GMD 100 F**  
**GMD 1021 F COMPACT**  
**GMD 10 - GMD 100 - GMD 105**



[www.kuhn.com](http://www.kuhn.com)



be strong, be **KUHN**

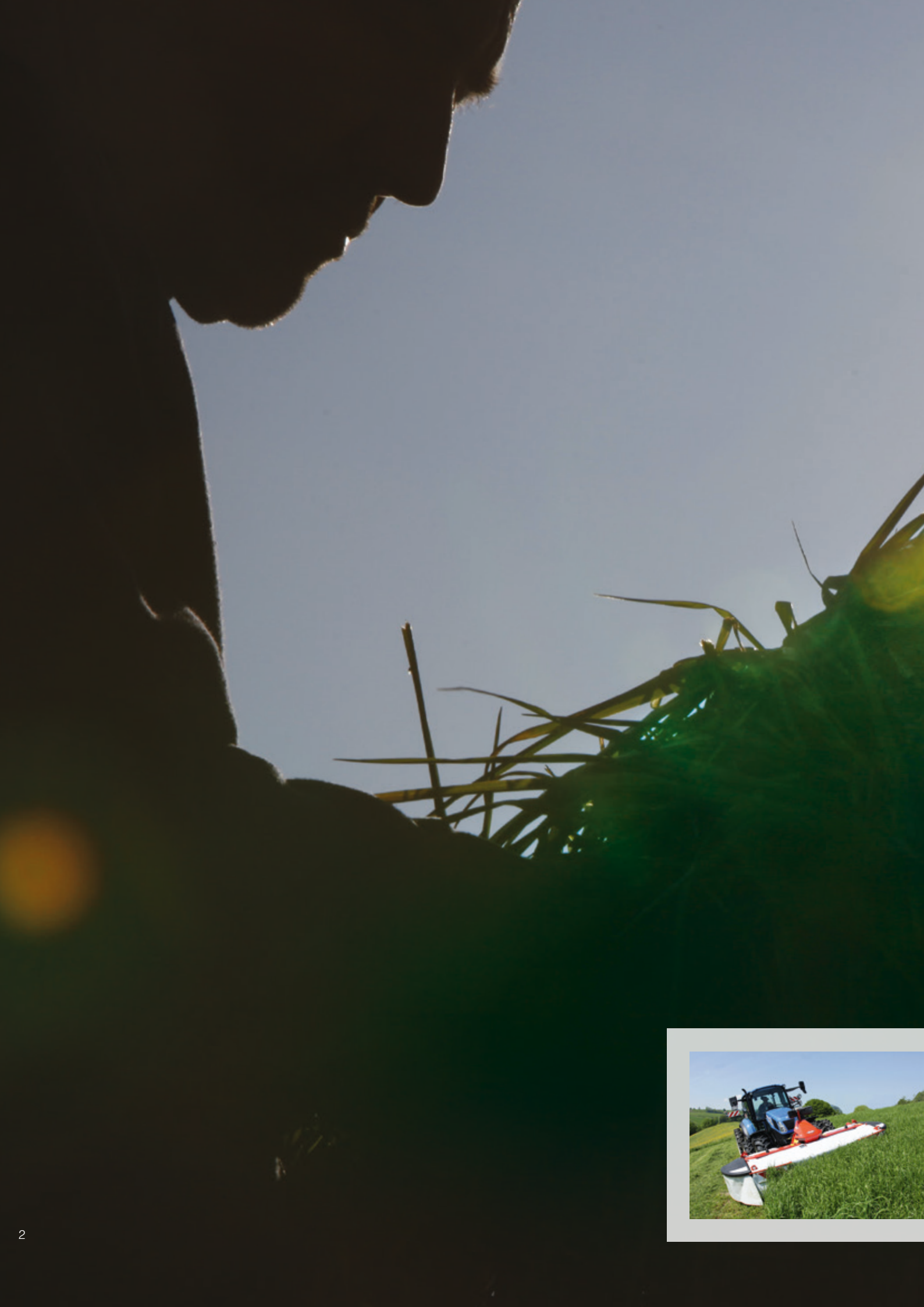

**GMD** 280 F 310 F 2721 F Compact 3121 F Compact

**GMD** 16 20 24 28 **GMD** 240 280 310 **GMD** 285 315 355

# BENEFIT FROM EXTENSIVE EXPERIENCE!



Today, all high-performance farms are aware of the importance of basic forage for their herds. All the extra energy available in the forage is reflected in higher productivity and hence higher revenues.

## HOW TO GET TOP-QUALITY FORAGE

You can count on KUHN mowers to have technologies that help you harvest clean forage, prevent recut and preserve the sward. They also integrate features to optimise ground pressure and transport.

## HOW TO SAVE TIME AND ENJOY STRESS-FREE USE

Our reliable cutter bars ensure longevity and limited down time. The important parts, such as the attachment frame, have been reinforced to enhance the stability of the machine.

## LOOKING FOR POWERFUL MOWING COMBINATIONS AND OPERATING COMFORT

Front-mounted mowers are the perfect implements to combine with other machines for high work output and increased efficiency. They are easy to handle, even when used as a combination.

### KUHN's GMDs in brief:

|                           | Working width (m) | Knife attachment  |
|---------------------------|-------------------|-------------------|
| <b>GMD 280 F</b>          | 2.80              | FAST-FIT or bolts |
| <b>GMD 310 F</b>          | 3.11              |                   |
| <b>GMD 2721 F Compact</b> | 2.70              | FAST-FIT          |
| <b>GMD 3121 F Compact</b> | 3.14              |                   |
| <b>GMD 16</b>             | 1.60              | bolts             |
| <b>GMD 20</b>             | 2.00              |                   |
| <b>GMD 24</b>             | 2.40              |                   |
| <b>GMD 28</b>             | 2.80              |                   |
| <b>GMD 240</b>            | 2.40              | FAST-FIT or bolts |
| <b>GMD 280</b>            | 2.80              |                   |
| <b>GMD 310</b>            | 3.10              |                   |
| <b>GMD 285</b>            | 2.80              | FAST-FIT          |
| <b>GMD 315</b>            | 3.10              |                   |
| <b>GMD 355</b>            | 3.50              |                   |





# SIMPLY GREAT FORAGE!

In the current climate of expensive concentrate prices and the need to increase productivity and cost-efficiency in milk and meat production, the value of forage in a basic ration is more important than ever. Mowing is the first important step in the hay and silage-making process and different methods can be used to ensure optimal nutritional value in the forage. By listening to farmers' needs and translating them into specific solutions, KUHN mowers have been upgraded in order to harvest all the goodness in the forage.

Find all the expertise KUHN has to offer on [forage.kuhn.com](http://forage.kuhn.com)



## CUTTING AT THE RIGHT HEIGHT

- Fewer impurities are introduced into the forage. Not only during mowing but also at every stage of the forage harvesting process.
- A good cutting height is important to favour high-value forage species. If the mower is too close to the ground, weeds and unwanted species may develop.
- Prairie yield and productivity are improved by preserving the tillering phase. The latter includes the plant's sugar reserves and new shoots.



## ENSURING A CLEAN AND EVEN CUT

Double cutting has to be prevented, as it results in leaf loss and damage to the forage which then becomes more prone to disease. That's why the cutter bar and discs have been designed to promote forage flow towards the swath and to prevent soil being incorporated into the forage.



## KUHN SOLUTIONS

An ideal and constant cutting height is obtained by simple adjustment of the top link. Lifting skids are optionally available, if higher cutting heights are required.

### Specially designed cutting unit

- The disc mower's bevelled knives ensure a high-quality, clean and even cut.
- The oval-shaped discs as well as the compact and streamlined profile of the cutter bar reduce soil and crop-residue accumulation.

### Converging disc rotation

On KUHN mowers, each pair of discs is driven with converging rotation. Be sure: No double cutting will degrade your forage.

### Perfect ground contouring

- The cutter bar is positioned close to the tractor wheels, ensuring quick adaptation when driving over rough terrain.
- Optimal mounting of the suspension ensures that the cutter bar is perfectly balanced.
- Precise ground-pressure adjustment.

In this way the sward is preserved and the forage is not contaminated.

- Mower stability also enables optimised working speeds.
- Easy swath clearing and headland turns thanks to the cylinder-operated lift system (GMD 240 to 355).
- Cutting width adapted to the surface area.

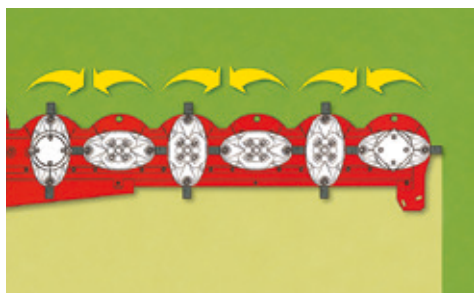

### GRASS MUST BE CUT NOT CHOPPED

The crop should be quickly ejected into the swath and only cut once. Double-cutting causes higher crop losses, delays regrowth and increases the power requirement on the tractor.

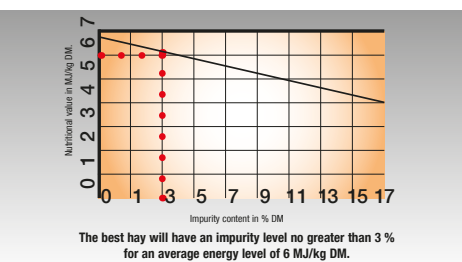

### PRESERVE PLANT COVER

The more productive the grassland is, the more prone it is to damage. Nevertheless, it is essential to preserve the sward. Otherwise, deep-rooting species, which are often undesirable (rumex, dandelions, etc.) would develop and impurities would be incorporated into the crop.



### MOW AT THE RIGHT TIME

Harvesting at the right moment, particularly for silage, means gaining the full value of forage plants: sugars, proteins, minerals and dry matter. Therefore, capitalizing on tight weather windows exactly when the forage is ready is an important building block to preserving forage quality.

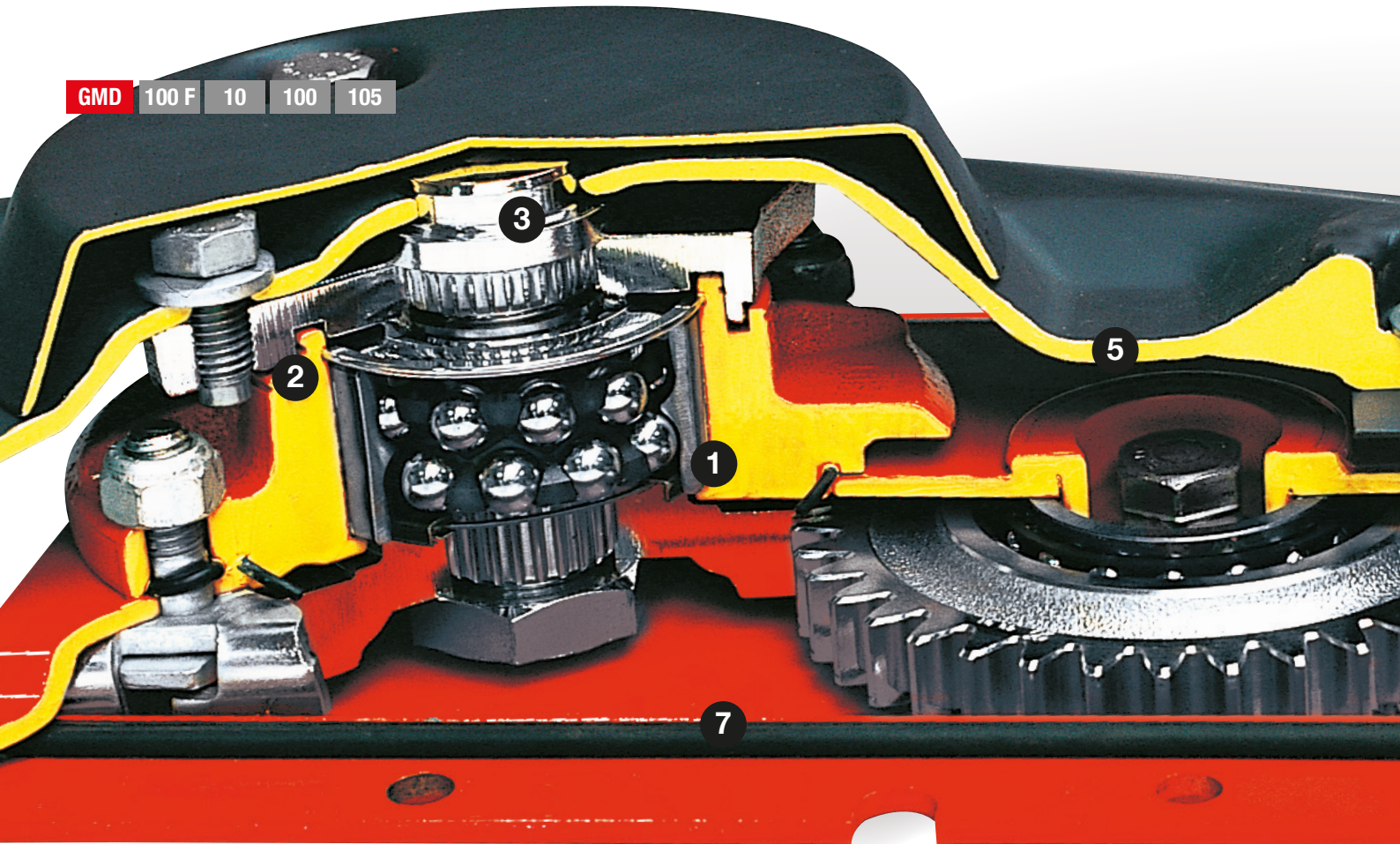

Some disc mowers may look like a KUHN from the outside. However what is on the inside is more important. KUHN's design and construction standards ensure a long life and reliable operations. Take a closer look yourself at what the 100 series cutter bar has to offer.

1. **Withstands the highest loads:** special high-capacity bearings fitted in a one-piece sealed housing not subject to distortion.
2. **Increased service life:** the disc pinion shaft bearings endure radial forces. This optimum position improves the load balance.
3. **Protection should an obstacle be struck:** the PROTECTADRIVE system is designed to protect the cutter bar gear train and minimizes downtime risks in peak season.
4. **Highly wear resistant:** knife-attachment hardware is fully protected. For added safety, heat treated steel cups are welded to the disc.
5. **Minimum wear and distortion risks:** idler gear fasteners are located in heat treated steel cups. Correct alignment is ensured with no risk of distortion.
6. **Long-term reliability:** large-diameter gearwheels in high tensile forged steel with reinforced teeth.
7. **Perfect sealing:** top-quality o-rings used on cutter bar bearing housings.



#### MINIMIZED DOWNTIME

- The disc bearing station can be removed and mounted quickly and easily. Any repairs are carried out at reduced costs, from the outside, with minimum downtime.
- Total safety in case an obstacle is struck: the threaded pins of the disc housings are solidly linked to the upper half-casing. There are no weak points and no risk of being ripped out.

# TAKE A CLOSER LOOK AT KUHN MOWERS' MASTERPIECE

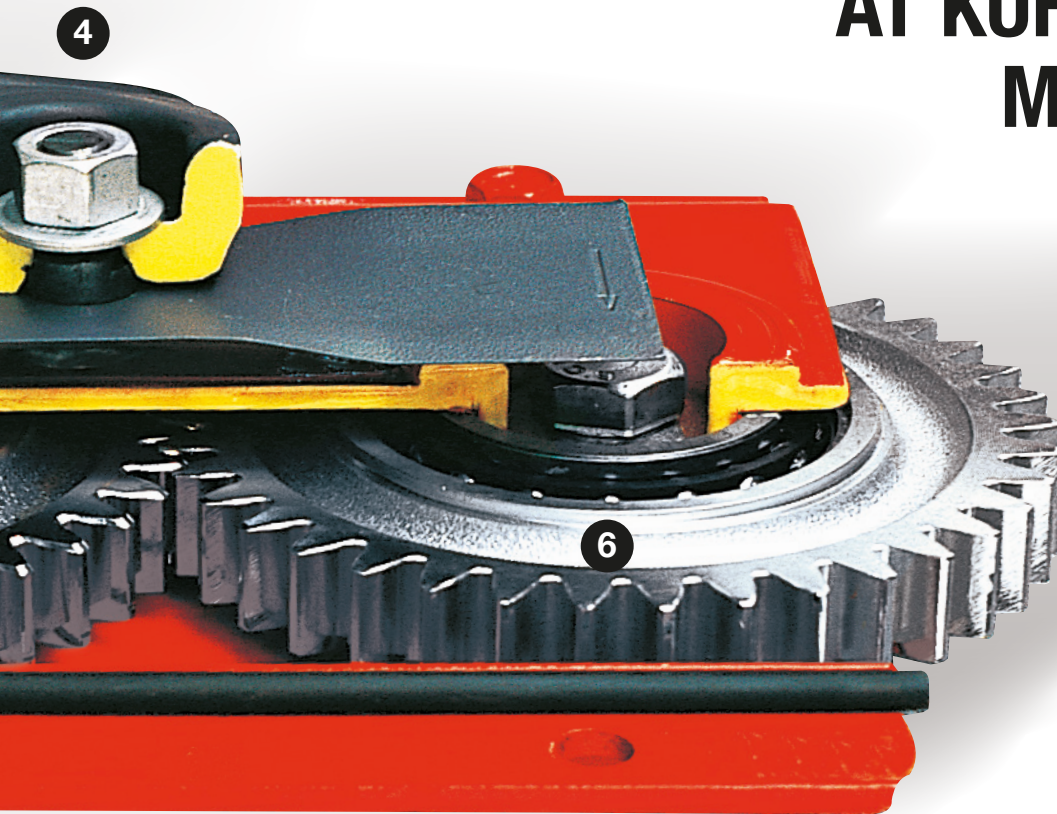

FAST-FIT ATTACHMENT :  
blades can be changed quickly.

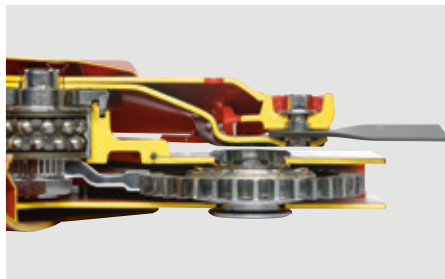

Bolt attachment

## FAST-FIT OR BOLTS = 100% SAFE KNIFE ATTACHMENT

GMD 280 - 310 F front mowers and GMD 240 to 355 disc mowers can be fitted with the FAST-FIT quick-release knife system. During the development phase, priority was put on ensuring that the FAST-FIT safety system was as the good as bolt attachment.

### 3 EXTRA GUARANTEES:

- A powerful leaf spring provides constant pressure to the knife retainer.
- The knife retaining pins are also equipped with a shoulder to provide an additional level of securement.
- The leaf spring can only be depressed to remove the knife at one point when the knife is centered over the shoe. Thus when the disc is rotating it is not possible for the knife to be released. To minimize costs the knife retention pin can be replaced separately from the leaf spring.

Cutting quality remains excellent owing to how compact the cutter bar is and the exclusive shape of the blades which move as close as possible to the guards.

# OPTIDISC ELITE: THE OPTIMUM CUT!

The profits that come from livestock farming are dependent on feed reserves stored in silos, bales or bulk. The aim is simple: to produce as much meat or milk as possible from the basic feed ration by optimising palatability. In order to do so, plant stubble has to be preserved and forage contamination from impurities kept to a minimum. KUHN has perfected the technical features of the mowers so that you get the best from your forage and increase your profits.

The OPTIDISC ELITE cutter bar was developed in partnership with the people who use it; farmers. It combines cutting quality, reliability and operating comfort. The very large knife overlap, reduced cut angle and converging disc rotation enhance the quality of the cut and send the forage to the swath.



## A CLEAN CUT IN ALL CONDITIONS

Great cutting quality is ensured in diverse forage types including in low mountainous regions with temporary meadows and natural grasslands.

Benefit from:

- Specially profiled discs.
- A large overlap.

The crop is carried away easily, especially on slopes, due to the "swathward" cut.



## EXCLUSIVE

### GLIDE ACROSS GRASS STUBBLE

In wet and sticky conditions earth can build up in front of the cutter bar; except with OPTIDISC ELITE! It comes with special skids that slide across the ground and preserve grass stubble. Yet another advantage for forage quality and a uniform cut, especially in difficult conditions.





## TOP-OF-THE-RANGE COMPONENTS REINFORCE THE MOST PRECIOUS PARTS OF THE CUTTER BAR

### EXTREME RELIABILITY AND HOLD

Top-of-the-range components reinforce the most precious parts of the cutter bar:

- Special disc-bearing station with a double row of angular contact ball bearings.
- Large-diameter gear wheels in high-precision forged steel with 3 cogs engaged.
- Discs with forged and treated cups across the surface area.
- Disc skids in treated steel with the option of adding a protective layer (screw on).
- PROTECTADRIVE safety.

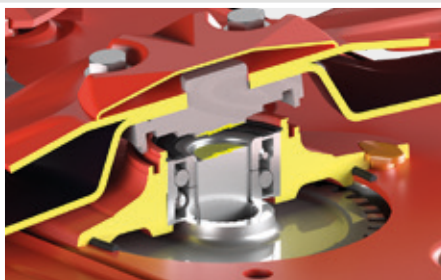

#### SAFETY

### PROTECTADRIVE: PROTECTION AND COST REDUCTION

In the event of a violent impact between a disc and an obstacle, the shaft holding the disc can shear just above the bearing thanks to a carefully dimensioned shear groove. The toothed wheels are protected. In less than 15 minutes, the machine is operational again and at a very low repair cost.

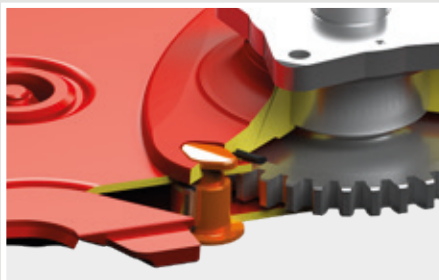

#### EXCLUSIVE

### EXTRA RIGIDITY WHERE IT COUNTS!

Disc-bearing stations are attached by long bolts that pass through the entire cutter bar. This eliminates any risk of the mounts being torn out of the cutter bar in case of impact. The disc-drive pinion is held in place with this highly reliable system that reduces repair costs.

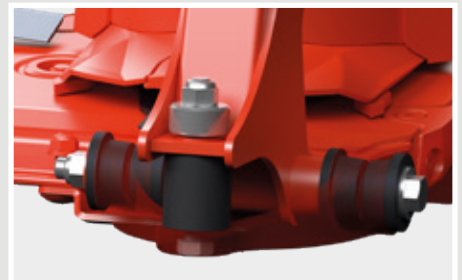

#### EXCLUSIVE

### LONGER MACHINE LIFE

Shock absorbers are integrated in the connection between cutter bar and chassis. The structure of the machine is less affected by impacts, especially when working at fast ground speeds.

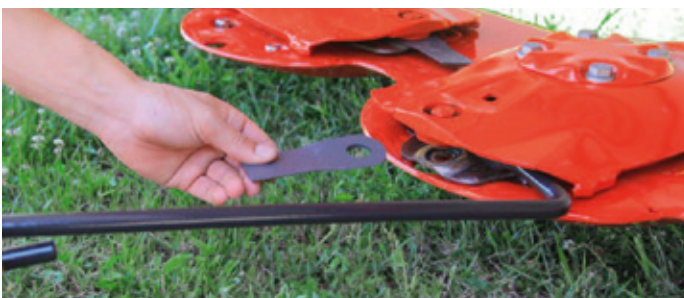

### FAST-FIT: KNIVES COMPLETELY SECURED

Mowers are equipped, as standard, with the FAST-FIT quick-release knife system. A powerful leaf spring provides constant pressure to the knife retainer for extra safety. It takes just a few moments to replace knives.



### KNIVES FREE TO ROTATE

For better cutting quality and a longer life, the knives rotate freely 360°.

**GMD 100 F**

# KUHN VERSATILE FRONT MOWERS FOR DIFF

Producing fodder of high nutritional value is your main aim during forage harvest. KUHN's new GMD 100 F series of front-mounted mowers is what you need. It has a wide range of equipment, provides reliability, a clean cut and excellent ground-contour following.



## **GMD 310 F**

This 8-disc front mower has a working width of 3.11 m. Its four swathing drums are important assets which form an airy swath and prevent it from being pressed down by the wheels of the tractor. The GMD 310 F mower has a transport width of less than 3.00 m.

**FIND MORE DETAILS  
ON PAGES 12-13**

## **GMD 280 F**

With its 7-disc cutter bar the GMD 280 F has a working width of 2.80 m.



# ERENT OPERATING CONDITIONS!

GMD 1021 F Compact front mowers have been especially developed for use in hilly areas. They are perfectly adapted to low-power tractors and specialised mountain tractors. Every detail has been taken care of in order to reduce weight as much as possible without compromising reliability.



## **GMD 2721 F AND GMD 3121 F**

These mowers are incomparably lightweight. They weigh 575 kg and 635 kg for working widths of 2.55 and 3.00 m respectively.

**FIND MORE DETAILS  
ON PAGES 14-15**

## **GMD 1021 F COMPACT**

The cutter bar, especially with twin wheel tractors or wide track, provides a large working width of 2.70 m and 3.14 m respectively for the GMD 2721 F and GMD 3121 F.

A large overlap zone prevents poorly cut areas in tight turns.



# FORAGE QUALITY

It's the quality of reserves stored in silos, bales, or bulk that makes an important difference for farmers who want to increase the profitability of their livestock. The aim is simple: produce as much meat or milk as possible from the basic feed ration.

## **MORE ROBUST AND COMFORTABLE**

In order to ensure extreme longevity, specific features have been integrated into the design:

- Very thick main frame.
- Drum drive reinforced with new bearings and seals.
- Transmission adapted to high-powered tractors as standard.
- New front access to greasing points.
- New side guards that do not need to be folded under the hood for transport.

## **PERFECTLY ADAPTED TO COMBINATION USE**

GMD 280 F and GMD 310 F mowers can reach cutting widths of up to 8.80 m when combined with a rear-mounted butterfly combination. With the lighter weight of these front models, high output is ensured even with medium-power tractors.



## HOW TO DELIVER A FLUFFY SWATH

Four belt-driven swath drums form fluffy, well-aired and narrow swaths, which will not be run over by the tractor wheels. This facilitates swath pick up by balers and forage wagons, with no risk of soiling the forage. In particular situations with heavy or long forage, serrated metal bars can be fitted on the drums to increase flow to the rear.



## «PULL TRAPEZIUM», SUPERIOR ADAPTATION TO IRREGULAR GROUND CONTOURS

The “trailed” mower unit is attached to the frame by rods. With the special suspension concept, it is able to pivot +/- 6° left to right as well as minus 6° down and plus 5° up, but can also travel 50 cm vertically - perfect prerequisites for excellent ground adaptation that result in clean forage, both during daily operations on soils that are often still wet or for hay and silage making.

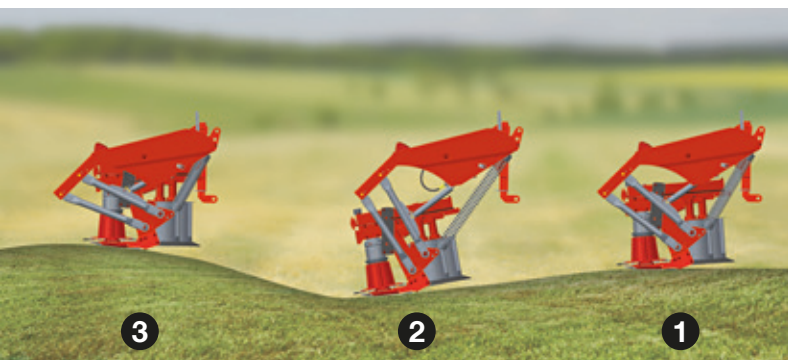

### WHEN FACED WITH AN OBSTACLE:

1. The mowing unit lifts like a ski tip.
2. Goes over the obstacle.
3. Moves back to its normal position automatically.

### ADAPTED GROUND PRESSURE

The optimum position of the suspension springs on GMD front mounted mowers provides for precise and fine-tuned ground-pressure adjustment. The weight the mower unit exerts on the ground is therefore limited efficiently at all times. In addition, this reduces skid wear. The result: Constant cutting height, preserved grass stubble and dirt-free crops.



# THE MOUNTAINEER AMONG FRONT MOWERS

Compact front mowers have been upgraded. The GMD 2721 F and GMD 3121 F come in 2 working widths. Their compact design and light weight makes them particularly adapted to hilly areas. It is impressive to see how well they cut and contour the ground when they are at work on slopes of over 30%.



## MINIMUM WEIGHT, MAXIMUM DEPENDABILITY

The compact design of GMD 2721 F and GMD 3121 F mowers is ideally adapted to small tractors. The light weight and skid shoes improve ground-contour following. The harmonious design of the machine avoids any superfluous weight while being robust and providing stability at work.





### PRECISE TERRAIN CONTOURING

The mowing unit adapts precisely to ground contours thanks to its pendulum-type articulation with travel range of +/-8°. Ground pressure adjustment is by two springs linked to the tractor or directly by the tractor's integrated front-lift suspension. Ground pressure is limited which protects plant cover.

« Perfect cut in all conditions. Many positive comments have been made on the excellent ground following and quality of cut. »

source : German magazine LANDWIRT 18/2018, p63.



### TWO TYPES OF LINKAGE

The mowers can either be mounted on a 3-point frame or a quick-hitch A-frame. For the latter a male A-frame is required.



### EXCLUSIVE

### FLEXPROTECT - AVOID REPAIR COSTS

To prevent tool damage while mowing along field edges or next to a tree, the flexible side guard, FLEXPROTECT, can bend in and out of shape. It is easy to deploy, no tools required, or a hydraulic remote control is available as an option.

# SIMPLE DESIGN. SUPERB CUTTING QUALITY.

The GMD 10 series is designed for small and medium-sized farms. With working widths of 1.6 to 2.8 m, these mowers have a simple structure with many features to ensure a clean cut. All models are equipped with the robust and effective 100 series cutter bar.



## SUSPENSION SPRING FOR ACCURATE GROUND ADAPTATION

The suspension spring allows accurate adaptation of cutter bar floatation to ground contours. Floatation-spring tension is determined by adjusting the main frame height using the tractor's 3-point lift.



## ARTICULATED UNIT TO FOLLOW CONTOURS CLOSELY

The articulated cutting unit follows ground contours with maximum accuracy, even when mowing banks and ditches.



## SAFETY BREAKAWAY MECHANISM

Should an obstacle be struck, the safety breakaway mechanism causes the mower unit to swing slightly backwards (up to 20°!). The impact is significantly reduced. You can reset the device simply by reversing.



# HOW TO ENSURE A CLEAN AND EVEN CUT

## THE CUTTER BAR FOLLOWS TERRAIN CHANGES INSTANTANEOUSLY

The distance between the cutter bar and the rear tractor wheels is very short. This enables the cutter bar to react quickly to changes in the terrain, and cutting height remains uniform.



## FOR COMPLETE FORAGE EVACUATION

The particular shape of the discs facilitates quick forage clearing to the rear. This prevents grass recut. The knives are attached to the discs with bolts.



## PERFECT SWATH FORMATION

The swath wheel is mounted behind the outer disc cone. It separates cut crop from uncut crop so that the tractor can drive over the ground rather than the previously cut crop.

The advantages of a swath wheel over a swath board:

- It fits entirely under the curtain.
- It is not in contact with the ground.
- Damage by backing or turning is avoided.



## PTO SHAFT WITH OVERRUNNING CLUTCH

A PTO shaft with overrunning clutch is recommended if the mower is attached to a tractor with an automatic, hydraulic PTO brake. Such an overrunning clutch is available as standard on the GMD 28 model.



# RELIABLE MOWERS TO COPE WITH EVER INCREASING WORK INTENSITY

As successors of the proven KUHN GMD 600, 700 and 800, the GMD 240, 280 and 310 models will win you over completely. They have been developed to adapt better to ever intensifying working conditions:

- larger surface areas to mow,
- higher mowing speeds,
- longer transport distances with speeds often reaching up to 40 or even 50 kph.



## SMOOTHER OPERATIONS ON HEADLANDS

To limit mower-unit lift in headland turn position, a **hydraulic shut-off valve** is used on GMD 240 to 310 models. This enables smoother operating and reduced mechanical loading.



## WITHSTANDING INCREASING CONSTRAINTS

In order to better withstand the constraints at work and during transport, a **reinforced attachment frame** has been introduced on all GMD 100 series models. It is capable of absorbing 70 % additional strain.



## A COVER FRAMEWORK

The design of the framework and cover ensures long-term reliability.

# SUPERB MOWING QUALITY

## EVEN FLOATATION OVER THE ENTIRE CUTTER BAR

A heavier compensating spring ensures that the cutter bar will operate with optimum ground pressure over a wide range of terrains.



## CLEVER KINETICS FOR PRESERVED PLANT COVER

The lift and suspension system allows both the cutter bar and the inner shoe to be raised off the ground using only the mower's hydraulic cylinder. This simplifies operations and increases productivity. The tractor's 3-point hitch stays at the same preset height.



## FULL RANGE OF OPERATING CAPABILITIES

With the kinetics of the mowing unit, +35° mowing banks and ditches is possible at a tilt angle of up to 35° and down to 25°, depending on the model.

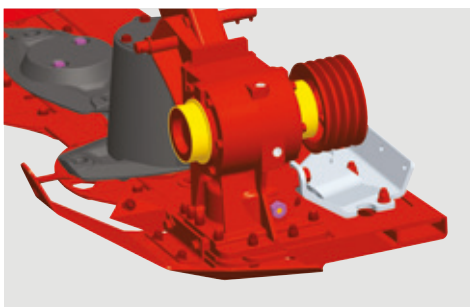

## REDIMENSIONED ARTICULATIONS

The main articulations of these machines have been redesigned to meet their **commitment to long-term robustness**: the cutter bar is articulated on bronze bushings.

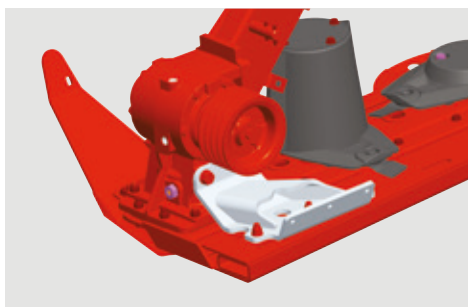

## REINFORCED LINK BETWEEN GEARBOX AND CUTTER BAR

A reinforcement bracket links the bevel gearbox to the rear cutter bar stiffener. **It makes the cutter bar over 40 % more resistant.**



## GOOD CLEARANCE BETWEEN MOWN AND NON-MOWN AREAS

When mowing long forage, high clearance is necessary at the end of the cutter bar. High clearance under the cover and swathing disc facilitates forage flow-through and the separation of cut from uncut forage.

# FROM WORK TO TRANSPORT IN THE BLINK OF AN EYE



## CHANGE TO TRANSPORT POSITION FROM THE CAB

GMD 240 to 310 models can be equipped with the optional hydraulic pivot system to transport position. This means that changing from work to transport mode has never been as quick and easy. You will especially appreciate the time saved when having to work in small fields.



# A WIDE CHOICE OF DISCS TO ADAPT TO EVERY SITUATION



## FAST-FIT DISCS

GMD 240, 280, and 310 mowers can be equipped with FAST-FIT knives. To minimize costs the knife-retention pin can be replaced separately from the leaf spring. Priority has been put on ensuring that the FAST-FIT safety system is as good as bolt attachment.



## STANDARD DISCS

Depending on the situation and intensity of use, knife attachment by bolt may be the right choice. These discs can be fitted with beveled knives (standard) or ribbed knives.



## HEAVY DUTY (HD) DISCS

The service life of these discs is superior to the others. They are adapted to intensive mowing conditions. GMD 100 series mowers can be equipped with these heavy discs as standard. Beveled knives are available as standard, ribbed knives as option.

# PRACTICAL FEATURES TO SAVE TIME AT WORK



## SEMI-AUTOMATIC BELT TENSION

The belts are readjusted during run-in. They feature easy and accurate adjustment of belt tension. And, as a KUHN exclusive, for increased belt life, proper pulley-to-pulley dimension is maintained regardless of the load on the belts.



## ONE TOOL FOR ALL ADJUSTMENTS

One tool, supplied with the mower, will perform all of the following tasks:

- adjustment of the floatation spring,
- unlocking the safety cover,
- belt tension adjustment,
- knife replacement (if bolted).



## NO TIME TO LOSE DURING THE BUSY SEASON

To save time during the season, GMD 240, 280, and 310 disc mowers are equipped with a drive shaft that lengthens greasing intervals to every 100 hours.



## Retain the resale value of your machine

Should an obstacle be encountered, the safety breakaway mechanism allows the mower to swing slightly rearwards (up to 20°). This significantly reduces the impact load on the cutter bar. The device is reset by simply backing up.



## KUHN PARTS

Designed and manufactured to rival time

KUHN foundries and forge as well as high-level manufacturing processes enable the production of spare parts that defy time. You can truly rely on our know-how and our genuine parts. Benefit from our client support and logistics services via any KUHN PARTS warehouse, which provide quick and reliable repair solutions in partnership with your nearest authorized KUHN dealer.



# DEFY THE LAWS OF UNEVEN TERRAIN!

Three new mower models have been created to complete KUHN's range of mowers. The GMD 285, 315 and 355 models are designed for farmers who need more effective ground following and forage evacuation to the rear on uneven plots and during swath recuts. This is possible thanks to the new CONSTANT FLOAT suspension system and the new direct control feature (via the cutter bar's first disc). With working widths from 2.8 to 3.5 m, the capacity of these machines to work at high speeds and at low power input makes them ideal for working large areas at lower costs without impacting mowing quality.



## SUPERB MOWING



### CONSTANT FLOAT

Owing to its very large spring, the mower unit's suspension system is worthy of a pendulum-type articulation system. It also ensures excellent machine stability, so cutting height is regular, even at high speeds, and ground hugging is optimum. The sward is protected, even when it is wet. Suspension adjustment is quick and easy: no tools are required.

### PIVOT MECHANISM WITH EXTREME OFFSET

The pivot release mechanism is offset to the extreme left of the machine and with 22° displacement to the rear. The machine absorbs shocks better in the event of impacting an obstacle.

### REGULAR SWATHS

The outside disc and swathing disc create a clear separation between standing forage and the swath as well as a clear passage for the right wheel of the tractor. The swath is well-shaped, uniform and easy to pick up.

# COMPACT ON THE ROAD



The improved linkage system adapts to different overall tractor widths. The design of the chassis and the drive system make the machine compact for transport. The end guard folds automatically to reduce transport height (on GMD 315 and 355). The machine is stored flat. If space is lacking, an additional parking stand (option) can be used to store the machine vertically in your shed.

# EASY MACHINE MAINTENANCE

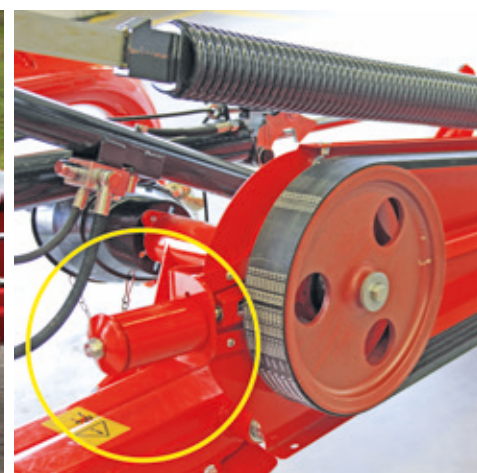

These GMD mowers have a new system of direct control **(A)** of the cutter bar that passes through the first disc. With high clearance, forage flows smoothly through to the rear of the machine, especially on uneven plots and when cutting the swath again. An external link **(B)** connects the cutter bar to the guard to provide the strength necessary for intensive operations. The cutter bar is accessible via a double opening in the curtain. Maintenance is much easier, largely due to being able to fold the front, rear and side guards **(C)**.

You'll save time on maintenance: the belt has a pre-tensioning system, there is no greaser on the machine and the main gearbox requires no oil change.

# CLEAN FORAGE AND PERFECTLY STRUCTURED SWATHS

Forage with high energy and nutritional values needs to be clean. This is key to increasing your herd's productivity. KUHN provides you with different solutions to calibrate your swaths effectively and meet your requirements.



## STANDARD: OUTER SWATH WHEEL FOR PERFECT SWATH FORMATION

A swath wheel is mounted behind the outer disc cone and separates cut from uncut crop. This means that the right-hand tractor wheels drive over the ground and not the previously cut crop. The advantages of a swath wheel over a swath board:

- It fits entirely under the curtain.
- It has no ground contact.
- Damage by backing up or turning is avoided.



## OPTION: INNER SWATH WHEEL FOR GMD 24 AND 240

This wheel reduces the swath width on the GMD 24 and 240 models to approximately 1.50 - 1.60 m (4'11" - 5'3").



## OPTION: SECOND INNER HIGH CONE FOR GMD 28 AND 280

To reduce swath width on these mowers, the second flat disc is replaced with a high cone that reduces swath width to approximately 1.70 - 1.80 m (5'7" - 5'11").



## OPTION: INNER SWATH WHEEL FOR GMD 28 AND 280

Used in connection with the second high cone, the inner swath wheel on GMD 28 and 280 will reduce the swath to approximately 1.50 m (4'11").





# GREAT TRACTOR-MOWER COMPATIBILITY



## STANDARD: OFFSET CAPABILITY

To ensure a full cut width when the mower is attached to tractors of varying track widths, GMD 240 to 310 mowers have an offset range of 50 mm to the left and to the right.



## OPTION: GREATER OFFSET CAPABILITY

An extended left hitch pin is available that increases the offset of GMD 240 to 310 models by up to 200 mm (8") to the right.



## QUICK-HITCH READY

GMD 240, 280 and 310 models are compatible with tractor attachments equipped with a Quick-Hitch frame, category 2. Simply mount an optional axle.



## OPTION: CUTTER BAR LIFTING SKIDS

These lifters are available for mowing conditions which require elevated cutting heights of up to 90 mm (3.54"). They will also prove useful in wet and sticky mowing conditions.

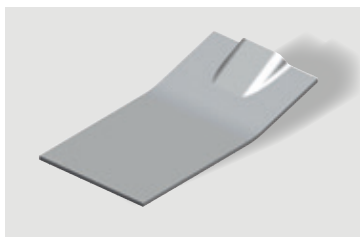

## OPTION: WEAR SKID

Wear skids are manufactured with great care to resist in abrasive soils. To reduce your maintenance costs, skid shoes can be welded to the bottom of skids in order to increase their service life.



## OPTION: EXTERNAL LINK ON GMD 10 AND 100

For very intensive use and on very hilly grounds: a connection bracket reinforces the link between the cutter bar and the cover frame.

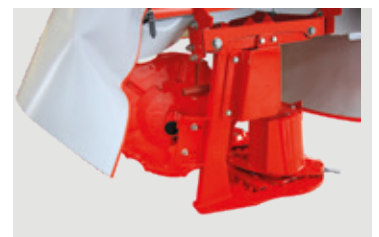

## STANDARD: EXTERNAL LINK ON GMD 105

GMD 105 series models come with an external link connecting the cutter bar to the guard, as standard. This is an advantage for very intensive operations, on rough ground and when mowing at high speeds.

## Technical specifications

|  | GMD 280 F                        | GMD 310 F | GMD 2721 F COMPACT                                   | GMD 3121 F COMPACT | GMD 16                                   | GMD 20 |
|--|----------------------------------|-----------|--|--------------------|--|--------|
| Working width (m)                                      | 2.80                             | 3.11      | 2.70   | 3.14               | 1.60                                     | 2.00   |
| Number of discs with protection skirts (treated steel) | 7                                | 8         | 6  | 7                  | 4  | 5      |
| Removable disc bearing stations                        |                                  |           |  |                    |  |        |
| Cutter bar   | 100 series                       |           | OPTIDISC ELITE                                       |                    |  |        |
| Gear train protection                                  | PROTECTADRIVE                    |           |  |                    |  |        |
| Suspension   | by spring                        |           | By spring or tractor lift                            |                    |  |        |
| Safety   | -                                |           |  |                    |  |        |
| Knife attachment                                       | Bolted or FAST-FIT quick release |           | FAST-FIT quick release                               |                    | Bolted                                   |        |
| Average swath width (m)                                | 0.90                             | 1.30      | 1.30   | 1.50               | 1.10                                     | 1.40   |
| Outer swath wheel                                      | -                                |           | By outer disc with cones                             |                    |  |        |
| Mowing angle   | +/- 6 %                          |           | +/- 8 °  |                    | +35° to -22°<br>(-40° with optional kit) |        |
| Headland turn position                                 | By integrated cylinders          |           | By tractor lift                                      |                    |  |        |
| Transport position                                     | -                                |           | -  |                    | Vertical folding hydraulic cylinder      |        |
| Linkage  | A-frame attachment cat. 2        |           | A-frame attachment cat. 2<br>or 3-point cat. 1 and 2 |                    | 3-point cat. 1 and 2                     |        |
| Quick Hitch compatibility                              | -                                |           |  |                    |  | -      |
| Chain limiter  | ◆                                |           | -  |                    | ◆  |        |
| PTO rotation speed (min <sup>-1</sup> )                | 1000                             |           | 540 or 1000  | 1000               |  |        |
| Primary drive shaft                                    |                                  |           |  |                    |  |        |
| Free wheel   | ◆                                |           |  |                    | ◇  |        |
| Min. PTO power requirement (kW/hp)                     | 28/38                            | 32/43     | 27/32  | 37/43              | 15/21                                    | 19/26  |
| Necessary tractor hydraulic equipment                  | 1 x SA                           |           | -  |                    | 1 x SA                                   |        |
| Weight (kg)  | 960                              | 1010      | 575  | 635                | 420                                      | 465    |

◆ as standard ◇ optional equipment -- not available

## KUHN SERVICES\*

Maximize the use and productivity of your kuhn equipment

\*Not all services and equipment are available in every country.

### KUHN sos order

#### EXPRESS SPARE PARTS SERVICE 24/7

You urgently need spare parts? With KUHN sos order benefit from express delivery seven days a week, 365 days a year. Thus, you can minimize machine downtime considerably and increase your work output.

### KUHN protect +

#### THE CHOICE OF PROFESSIONALS!

Benefit from 36 months in complete serenity because of KUHN's protect+ warranty. You can concentrate exclusively on your work and the performance of your machine. Because this is what you expect, when investing in high-tech machinery.

### KUHN i tech

#### FOR EVER QUICKER REPAIRS!

An unexpected technical problem always occurs at the wrong time. Your KUHN dealer can support you quickly and efficiently thanks to KUHN i tech. With this 24/7 online service, a quick and exact diagnosis is possible.

### KUHN finance

#### INVEST RATIONALLY!

New machine necessary, financing unsure? Modernize your equipment and develop your farm with KUHN finance, in total safety and according to your needs and demands. We offer custom-made finance solutions, adapted to your requirements.

## Mounted Disc Mowers

| GMD 24   | GMD 28 | GMD 240   | GMD 280 | GMD 310                | GMD 285                  | GMD 315      | GMD 355 |
|--|--------|---|---------|------------------------|--------------------------|--------------|---------|
| 2.40   | 2.80   | 2.40  | 2.80    | 3.10                   | 2.80                     | 3.10         | 3.50    |
| 6  | 7      | 6   | 7       | 8                      | 7                        | 8            | 9       |
| ◆  |        |   |         |                        |                          |              |         |
| 100 series   |        |   |         |                        |                          |              |         |
| PROTECTADRIVE  |        |   |         |                        |                          |              |         |
| by spring  |        |   |         |                        |                          |              |         |
| ◆ (by mechanical lock)   |        |   |         |                        |                          |              |         |
| FAST-FIT quick release or bolted                                     |        |   |         | FAST-FIT quick release |                          |              |         |
| 1.70   | 2.00   | 1.70  | 2.00    | 2.40                   | 2.00                     | 2.80         | 2.80    |
| ◆  |        |   |         |                        |                          |              |         |
| +35° to -15°   |        | +35° to -25°  |         | +35° to -30°           |                          | +35° to -25° |         |
| by integrated hydraulic cylinder                                     |        |   |         |                        |                          |              |         |
| and automatic locking  |        | vertical folding after manual folding of safety cover<br>OR hydraulic vertical rear folding |         |                        | vertical folding to 110° |              |         |
| 3-point, cat. 2  |        |   |         |                        |                          |              |         |
| ◆  |        |   |         | ◆                      |                          |              |         |
| 540 (1,000 on GMD 310, 285, 315 and 355 as an option)                |        |   |         |                        |                          |              |         |
| 1 3/8 (6 splines)  |        |   |         |                        |                          |              |         |
| ◆  |        |   |         |                        |                          |              |         |
| 23/31  | 27/36  | 23/31   | 27/36   | 30/41                  | 2737                     | 30/41        | 34/46   |
| 1 x SA (+ 1 x DA for optional rear pivoting into transport position) |        |   |         |                        | 1 x SA                   |              |         |
| 544  | 600    | 613   | 659     | 711                    | 795                      | 845          | 875     |

## FOR AN EFFECTIVE FORAGE-HARVESTING CHAIN

The forage-harvesting chain is only as strong as its weakest link. It's important that all machines are complementary. The KUHN ForageXpert app can assist you in optimizing your harvesting processes with your current equipment in mind. With this tool, find the mower, mower conditioner, tedder and rake that are best adapted to your existing forage machines.

Available on the Apple Store as well as Google Play.

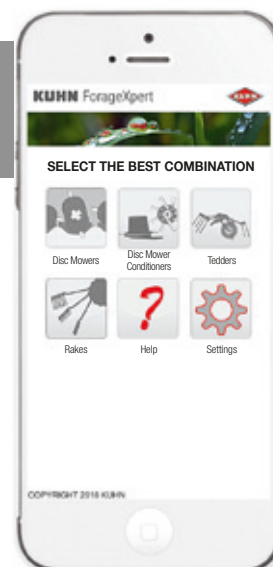

GMD 10 100 105

# FIND THE MOWER THAT MEETS YOUR NEEDS

GMD

Mounted Disc Mowers

|   | 285 to 355 | 240 to 310 | 16 to 28 |
|---|------------|------------|----------|
| Operating intensity                           | +++        | +++        | ++       |
| Easy transport/work position setting*         | +++        | +++        | +        |
| Easy knife replacement**                      | +++        | +++        | +        |
| Adaptation to tractors with large wheel track | +++        | +++        | +        |
| Simplicity and accessibility for maintenance  | +++        | ++         | +        |

\*with hydraulic pivot to the rear on GMD 240 to 310 \*\*with FAST-FIT knife attachment

+++ optimal ++ very good + good

## CHECK OUT KUHN'S EXTENSIVE RANGE OF HAY AND SILAGE-MAKING IMPLEMENTS



1. Compact front-mounted disc mowers - 2. Front-mounted disc mowers - 3. Horizontal-fold disc mowers  
4. Front / rear-mounted drum mowers - 5. Triple-head disc mowers - 6. Triple-head disc mower conditioners.

For more information about your nearest KUHN dealer, visit our website [www.kuhn.com](http://www.kuhn.com)

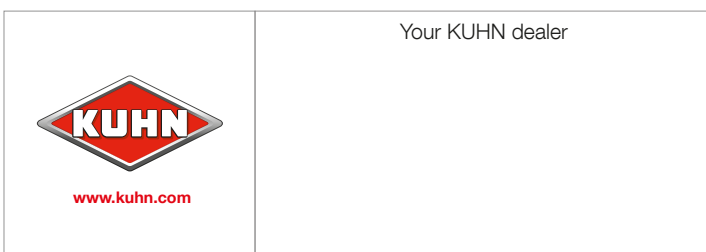
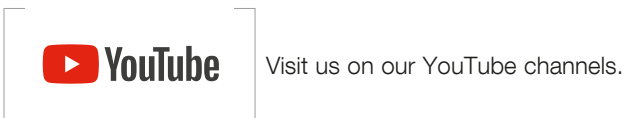

### KUHN SAS

4 Impasse des Fabriques - BP 50060 - F-67706 Saverne CEDEX - FRANCE

### KUHN NORTH AMERICA, INC.

1501 West Seventh Avenue - Brodhead, WI 53520 - USA

### KUHN FARM MACHINERY PTY. LTD

313-325 Foleys Road - Deer Park, VIC, 3023 - AUSTRALIA

### KUHN FARM MACHINERY (U.K.) LTD

Stafford Park 7 - GB TELFORD/ SHROPS TF3 3BQ

Information given in this document is only for information purposes and is non-contractual. Our machines are in compliance with regulations in force in the country of delivery. In our literature, and for improved illustration of certain details, some safety devices may not be in operating position. When operating these machines, these devices must be in position in accordance with the requirements indicated in the operator's manuals and assembly manuals. Respect the tractor gross vehicle weight rating, its lift capacity and maximum load per axle and tyres. The tractor front axle load must always comply with the regulations of the country of delivery (In Europe, it must reach minimum 20 % of the tractor net weight). We reserve the right to change any designs, specifications or materials listed without further notice. Machines and equipment in this document can be covered by at least one patent and/or registered design. Trademarks cited in this document may be registered in one or several countries.

Also find KUHN on